

## Saw Unit Settings

Product: Hydraulic Saw Unit  
Type: 10 – 19cc Saw Unit

Groeneveldt Grijpers B.V.  
Edisonweg 9  
2964 LK Groot-Ammers  
Netherlands  
Phone: +31 (0) 184-601545  
Email: info@ggbv.nl  
Website: www.ggbv.nl

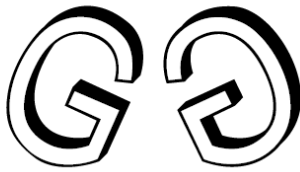

## Index

1. Assembling the Saw unit .....	2
1.1 Assembly Instructions.....	2
1.2 Assembling the Saw unit.....	2
2. Adjusting the Saw unit.....	3
2.1 Saw Unit Settings .....	4
3. Lubrication of the Saw unit .....	7
4. Refilling the Accumulator .....	8
5. Chaining the bar and chain.....	9
6. Fault Overview.....	10
7. Maintenance of Saw Bars and Chains .....	11
8. Saw unit diagrams .....	14
8.1 Electrical Diagram – Grapple + Saw unit.....	14
8.2 Hydraulic Diagram – Grapple + Saw unit .....	15
8.3 Hydraulic Diagram - Saw Unit Manifold.....	16

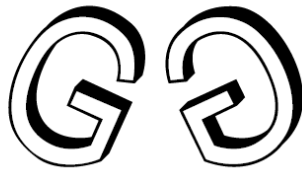

## 1. Assembling the Saw unit

### 1.1 Assembly Instructions

- The hydraulic installation of the crane must be suitable for the supply of the gripper, use only by Groeneveldt Grijpers B.V. or by the machine manufacturer supplied coupling parts.
- Make sure that the connector is suitable for the crane.
- The hydraulic connection must be made with a suitable hose that can withstand the maximum pressure.
- Lubricate the gripper completely and fill the oil tank with sawing oil.
- Check the gripper for any oil leaks.
- Check that the oil supply hoses are long enough so that they are not damaged when the gripper swings.
- Make sure that the leakage hose is connected at all times (Red hose).

### 1.2 Assembling the Saw unit

The Saw unit is connected to the gripper by performing the following steps.

1. Lift the Saw unit at the lifting point and position it with the quick coupling on the upper shaft of the gripper (Pos 1.)
2. Tighten the 2 bolts (Pos 3.) on the bottom of the quick coupling. By tightening the bolts (Pos 3.), the locking shaft is turned downwards (Pos 2.)
3. Tighten the bolts at the right time.
4. Connect the hydraulic hoses to the gripper and tighten it properly.
5. Connect (if necessary) the electric switch wire with foot pedal. The foot pedal is powered by connecting it with the plug in the cabin.
6. Make sure your machine settings are correct. A chain with too much speed, perhaps due to increased pressure/flow rates, increases the chance of a chain slipping away.

For decoupling, a reverse work sequence can be used.

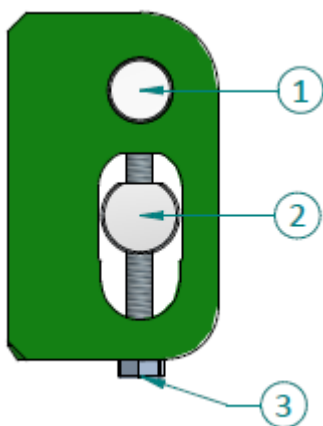



## 2. Adjusting the Saw unit

Assemble the gripper including Saw unit to the base machine.

Make sure that all hoses are properly connected by tightening them firmly!

Also the hoses between the Saw unit and gripper. Make sure that gallons of the machine are set correctly We recommend that you adjust the machine as high as possible. As a result, the saw functions best. Always use the same settings of the machine when cutting.

Oil Flow 10cc Saw unit: 60 – 100 l/min

Oil Flow 10cc Saw unit: 120 – 160 l/min

We recommend using a new sharp chain and a new bar when adjusting the Saw unit.

By operating the double-action function and additional foot pedal of the Saw unit at the same time, the saw will come out of the cabinet. During sawing, the double-action function and foot pedal must be held.

The pressure gauge for reading the pressure is incorporated into the frame of the Saw unit. To adjust the Saw unit, various settings of the manifold must be adjusted. This manifold is incorporated under the hood of the Saw unit.

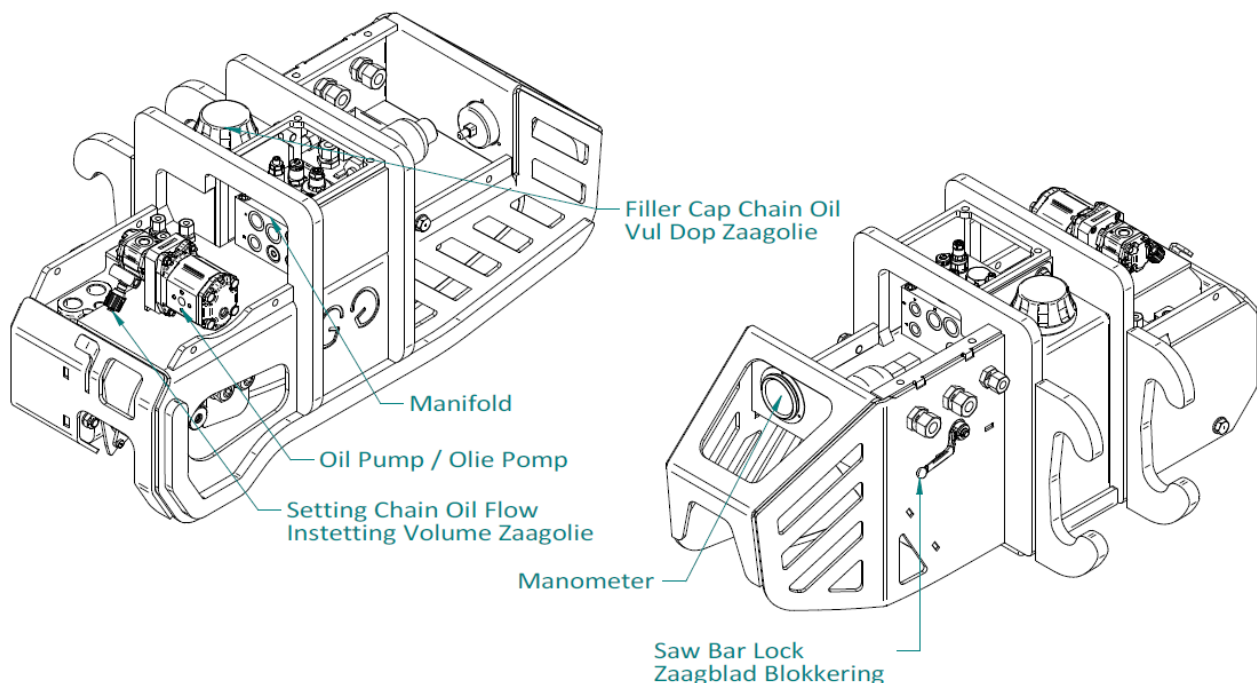

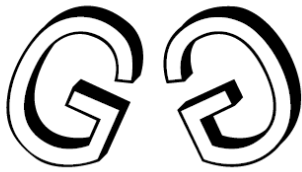

## 2.1 Saw Unit Settings

Now the Saw unit has to be adjusted to the correct adjustment, for this you have to be with two people at all times.

A person operating the excavator and a person adjusting the Saw unit.

At the bottom is an overview of the different measuring points and settings.

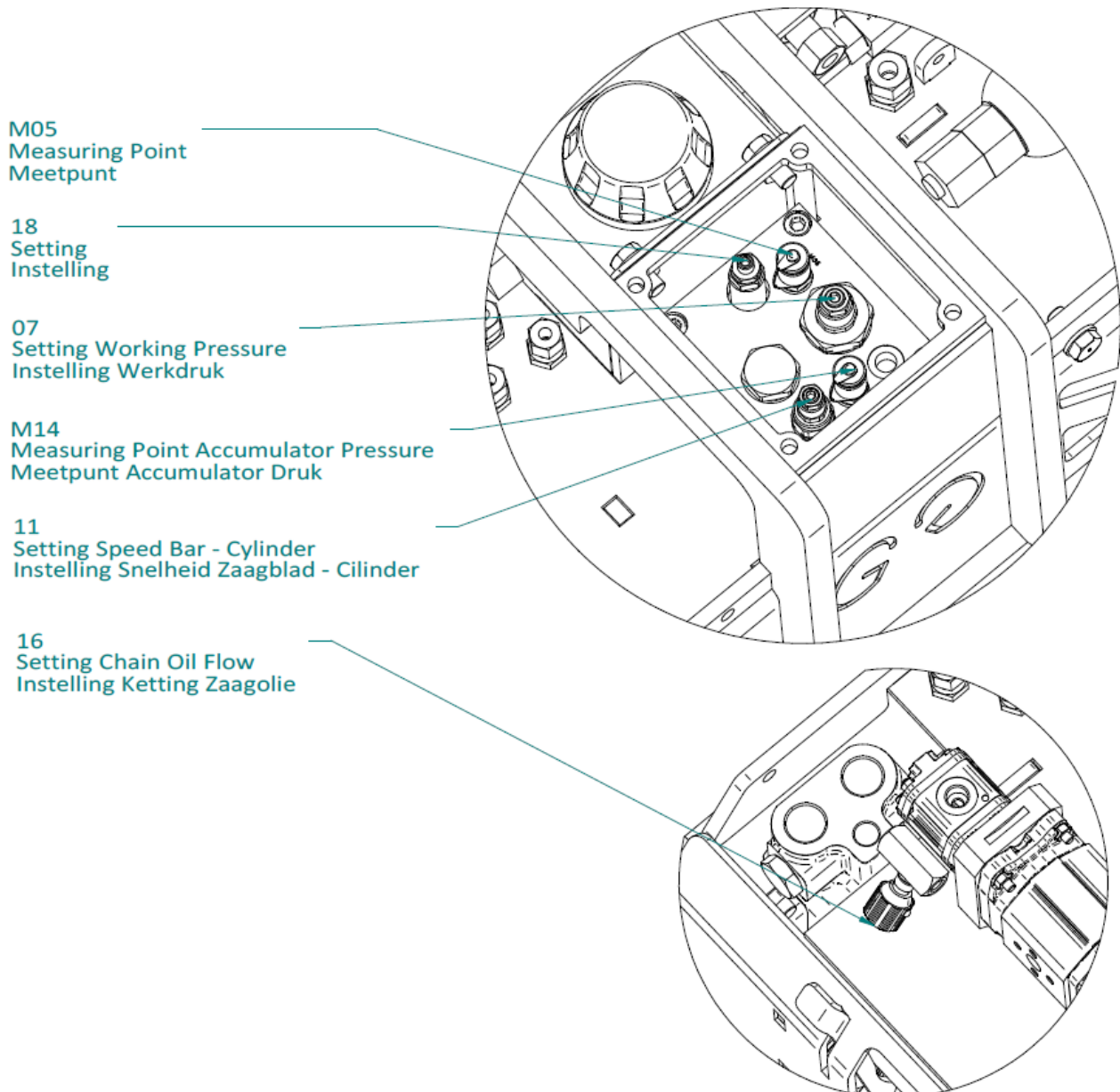

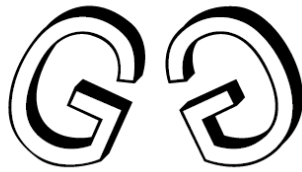

**STEP 1:** Setting 18 must be turned all the way in/closed. (clockwise)  
(Factory setting, this setting will no longer be used)

**STEP 2:** Make sure that the oil flow of the base machine for the double-acting function of the gripper/Saw unit is set to the right oil flow.

Oil Flow 10cc Saw Unit = 60 - 100 l/min

Oil Flow 19cc Saw Unit = 120 - 160 l/min

**STEP 3:** Connect a separate pressure gauge to the leakage oil measuring point.  
(This is located between the Saw unit and the gripper.)

**STEP 4:** Check the leakage pressure.

This should not exceed a maximum of 8 Bar during sawing.

**CAUTION:** Continuously check this leakage pressure during adjustment.



**STEP 5:** Setting 07 must be turned all the way back/up (counterclockwise).

**STEP 6:** Turn on the Saw unit by operating the machine. By operating the double-acting function and foot pedal at the same time, the saw motor will rotate.

Set the working pressure to 115 BAR by turning in Setting 07 gently.

The working pressure can be read on the pressure gauge. (Saw unit active)

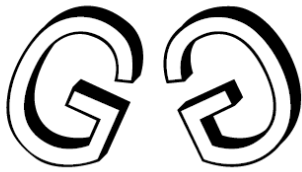

**STEP 7:** Set the saw blade speed by turning **Setting 11** on or off.  
This can be set to your liking depending on the type of wood.

**STEP 8:** The amount of chainsaw oil from the lubrication pump can also be adjusted by means of a loose throttle. This can be done by turning the **Smoring 16** in or out. The throttle may be opened a maximum of 1 whole turn further.

**STEP 9:** Check that the accumulator is set to approx. **50 bar**.  
This can be checked by connecting the dial gauge to **M14**.

**Make sure that the throttling of the filling set is closed during checking!**

The accumulator ensures that the saw blade returns to the Saw unit. If the saw blade does not go back completely, it may be that the pressure in the accumulator is too low.  
The accumulator can be adjusted by following **Chapter 4**.

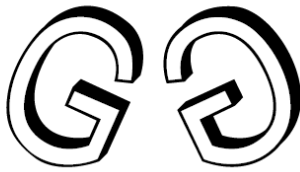

### 3. Lubrication of the Saw unit

The Saw unit is equipped with various lubrication points.  
Like the cylinder tips, these have to be lubricated manually.

The chain is automatically lubricated with oil by the lubrication pump.

The saw oil tank is located in the Saw unit. On top of the Saw unit is the cap of this tank. The saw oil tank must be filled every day and before the start of work.

Lubrication is extremely important, and that the right lubricating oil, and that oil, actually arrives where it is needed. Chain oil protects against wear, foaming and rust, and keeps the oil and tank clean to extend the life of the oil pump, chain and blade.

- Use a suitable lubricant.
- Never use used or previously used oil.
- The hydraulic oil must not contain dirt and water.
- We recommend bio saw oil ISO VG68 or VG150.
- The hydraulic oil of the saw oil pump must have a purity level from 19/17/14 to ISO 4406 or better.

The flow rate of the lubrication pump can be adjusted by opening the throttle at the rotary pump. The throttle is set correctly by first closing the throttle all the way to the right. In addition, the throttle must be opened a quarter of a turn to the left to allow enough oil to pass through. The throttle and pump are incorporated under the hood of the Saw unit.

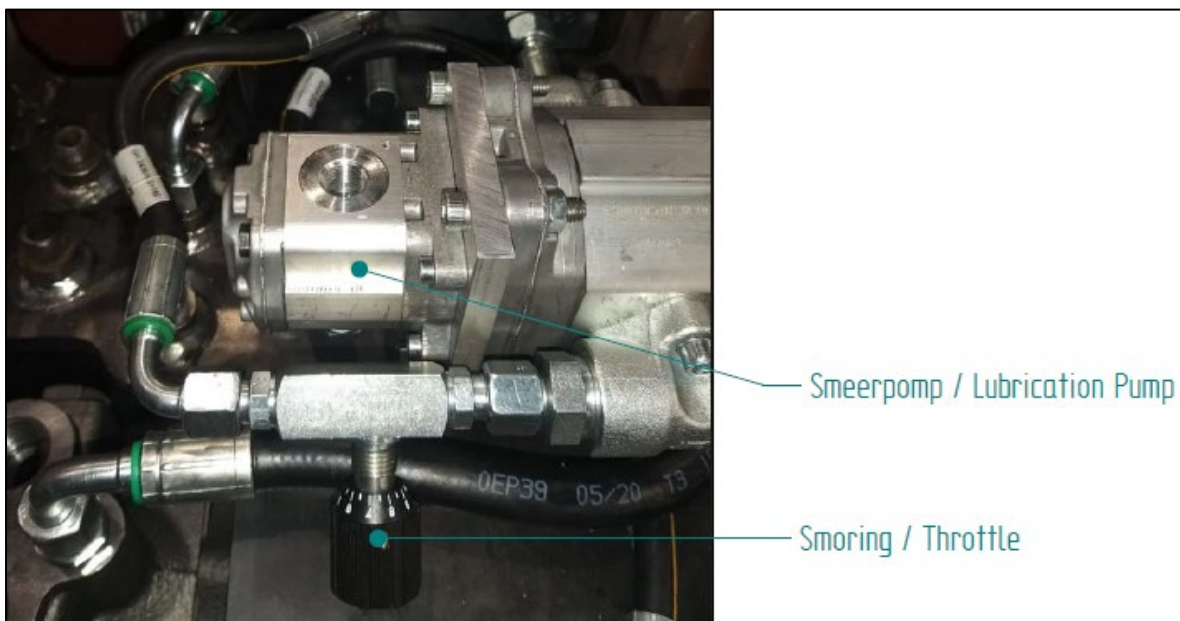

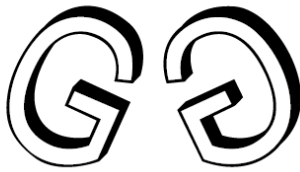

#### 4. Refilling the Accumulator

The accumulator ensures that the saw blade returns to the Saw unit. If the saw blade does not go back completely, it may be that the pressure in the accumulator is too low. The pressure in the accumulator must be approx. **50 bar** . If the above problem occurs, you can check the pressure with the supplied accumulator fill-set.

First of all, remove the covers so that you can easily access the accumulator and connection points.

##### Filling an accumulator

To increase the pressure, two people must be present at all times .

- The shut-off valve must be turned off before filling the accumulator.
- The measuring point on the pressure gauge side of the set must be connected to the measuring point **M14**.
- The measuring point on the valve side of the set must be connected to measuring point **M05**.

After connecting, the pressure that prevails in the accumulator can be read. If it is too low, you must perform the following actions. The operator has to operate the sawing function for a short time each time, the 2nd person has to read the pressure gauge until it reaches **50 bar**.

If the pressure rises too far, the throttle can be opened slightly, which reduces the pressure.

If the pressure does not drop, the tap side must be disconnected to allow the oil to drain manually.

When the pressure remains at 50 bar, you can disassemble the pressure gauge and increase the pressure is done.



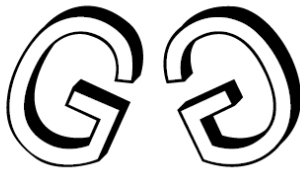

## 5. Chaining the bar and chain

If the chain breaks, it can lead to serious accidents, which is why it is strictly forbidden to be within the danger zone. When changing the chain, you should fit a sharp, checked, or new chain. When using a good chain, the risk of a breakage is a lot smaller than with a blunt chain.

When you install a new 'dry' saw blade, you should always lubricate the jockey wheel first. A bent saw blade can be aimed as long as there are no sharp bends and the grooves are not damaged. Especially after aligning a blade, the chain should be checked over the entire groove to make sure it runs smoothly.

In order to replace the saw blade and chain or to tighten the chain, the ball valve **(1)** must be closed. This is located on the back of the Saw Unit. After operating the saw function, the saw bar will remain out.

When the nuts **(2)** are loosened, the chain can be tightened or relaxed by loosening or tightening the adjustment bolt **(3)**. Before changing the bar and/or chain, the nuts **(2)** must be loosened further so that the clamping plate **(4)** can be raised.

Make sure that during assembly, the clamping block is back in the transport slot of the saw blade. Be sure to mount the chain in the correct cutting direction.

If the chain is relaxed, the bar and/or chain can be changed. By retracting the bar, the chain can be removed. After this, the blade can be changed by sliding it out. The same story applies to editing, only in reverse order. Once the change or adjustment has been done, the Saw unit is ready for use. When the change or adjustment has been done, the ball valve **(7)** can be opened again so that the saw blade is pulled back into the cabinet.

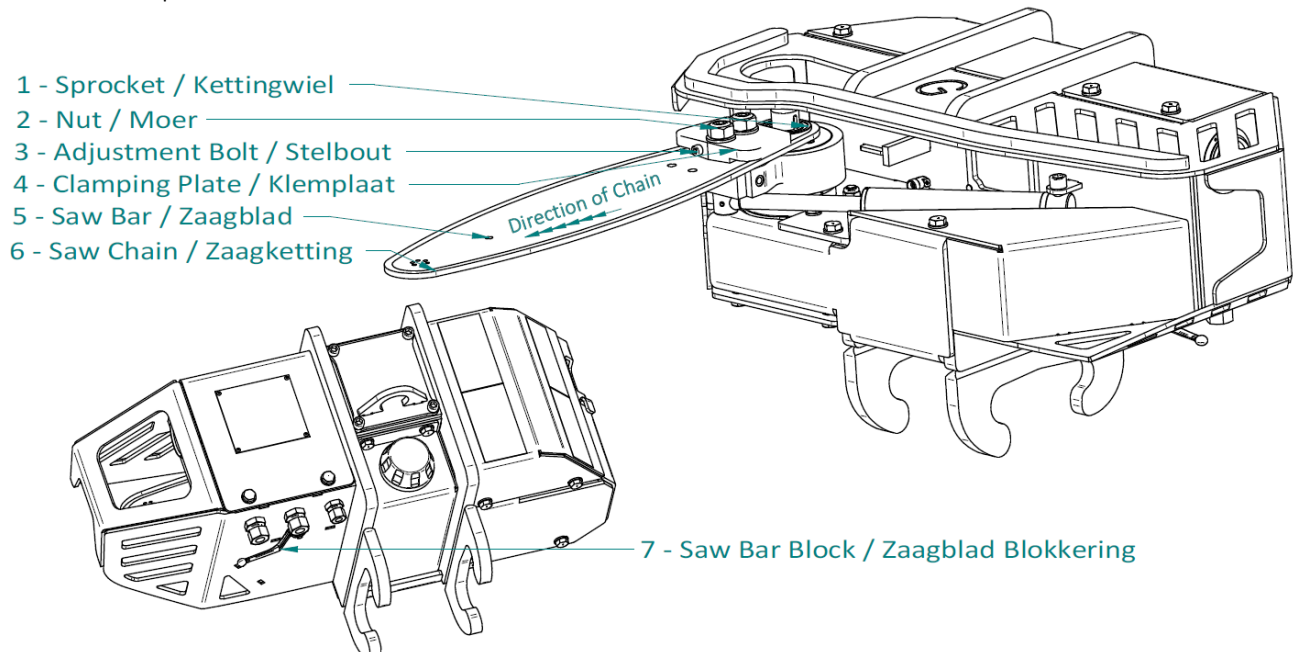

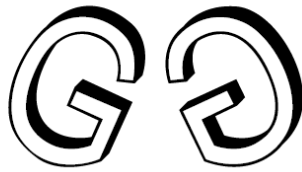

## 6. Fault Overview

Disturbance	Cause	Solution
Saw unit no longer responds	1. Hoses not properly fastened 2. Electric valve does not switch	1. Fasten hoses. 2. Check if the coils are magnetic.
Saw motor running but blade does not come out	System pressure of 115 bar not (anymore) present	1. Check the flow machine 2. See commissioning the Saw unit
System pressure too low	1. Machine gives less oil. 2. Adjustment option has expired.	1. Controlling the flow. 2. See commissioning the Saw unit
Saw blade won't go back into the closet	1. Accumulator pressure low.2. Leak pipe not connected properly. 3. Rotary knob blade lock.	1. Put accumulator on pressure. See commissioning the Saw unit.2. Check that the leak line is properly installed
Pressure on M05 but saw chain does not turn.	1. Nose wheel saw blade is stuck. 2. Return oil line not properly assembled.	1. Replace saw blade. 2. Check that hoses are properly mounted.
Saw blade strikes the log/wood	1. Setting expired. 2. Pressure system too high	1. Readjust with (11) 2. Check system pressure.
Saw blade won't turn off.	1. System pressure too low 2. Accumulator pressure too high.	1. Check system pressure 2. Check battery pressure
Doesn't cut the trunk all the way through.	1. System pressure too low 2. Accumulator pressure too high. 3. Saw chain not good	1. Check system pressure 2. Check battery pressure 3. Replace saw chain
Saw unit is difficult to cut and doesn't have nice curls.	1. Saw chain bot. 2. Cutting speed too slow.	1. Sharpen saw chain, replace saw chain. 2. Adjust speed. (11)
No lubrication of the saw chain.	1. Lubricating Oil Tank Empty 2. Oil pump does not run. 3. Pipe clogged.	1. Fill the tank 2. Check system. 3. Clean system.
Lubrication pump does not work or gives too much oil.	Pump/Motor does not run or runs too hard.	Adjust throttling of the oil pump.

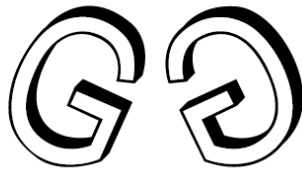

## 7. Maintenance of Saw Bars and Chains

- Replace a worn-out saw chain, blade, and sprocket.
- Replace a sprocket in time if it is worn out.
- We recommend replacing the sprocket every 10 chains.
- Make sure the chain is always tensioned.
- Make sure the chain catcher is always fitted
- Clean the chain groove when replacing the chain
- Only use blades with a straight chain groove.
- Replace crooked blades and never press them straight!
- Make sure the chain catcher is always fitted.
- Use only original saw parts.
- Make sure the blade is well lubricated, check the saw oil.

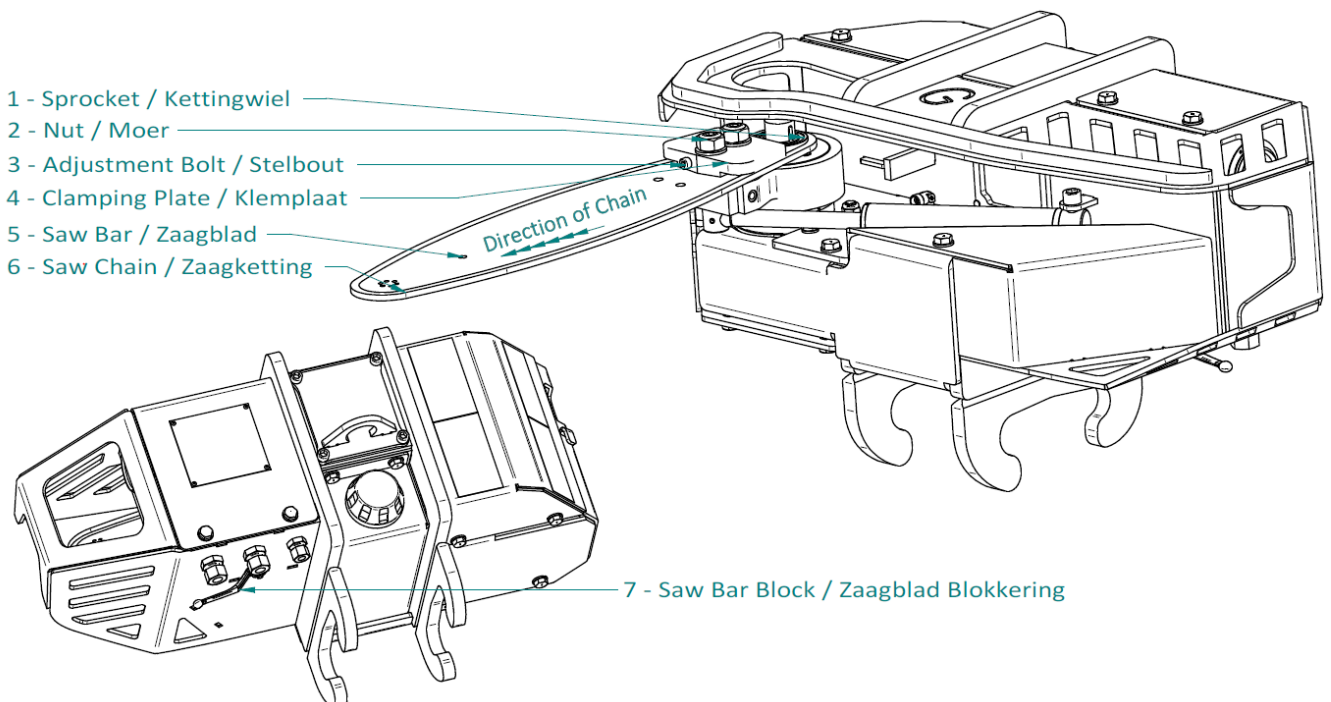

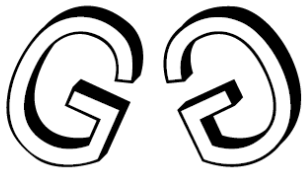

### Normal Guide Rail

A correct condition of the guide rail results in optimal cutting performance.



### Worn guide rail

The chain tilts in groove and does not cut straight. The underside and side of the chain wear out extra quickly. Replace the blade.

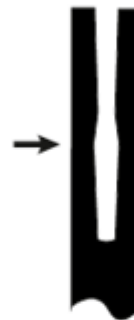

### Uneven guide rail.

Uneven rail wear, where the chain leans on one side and does not cut straight. Replace the blade.



### Clamping/closed guide rail.

This will cause the chain to jam and the blade from cutting through the wood properly. Replace the blade or open the groove



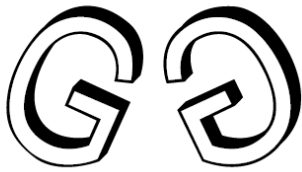

**Excessive wear on the blade.**

This is due to a loose chain tension and causes material wear on the blade.

Adjust the chain tension.



**The nose of the leaf turns blue**

The nose or guide rails are pinched.

Causing friction due to the spinning gear. Replace the blade sprocket to avoid further problems.



**Wear on sprocket**

Loose chain tension or too much bar pressure.

This causes crumbling at the nose joint.

Replace the nose and clean the guide rails.

If the end of the saw blade is severely damaged, the saw blade must be replaced.

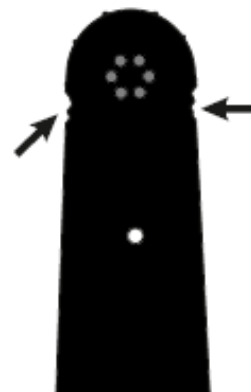



## 8. Saw unit diagrams

### 8.1 Electrical Diagram – Grapple + Saw unit

Equipped with standard switch set with foot or hand switch.

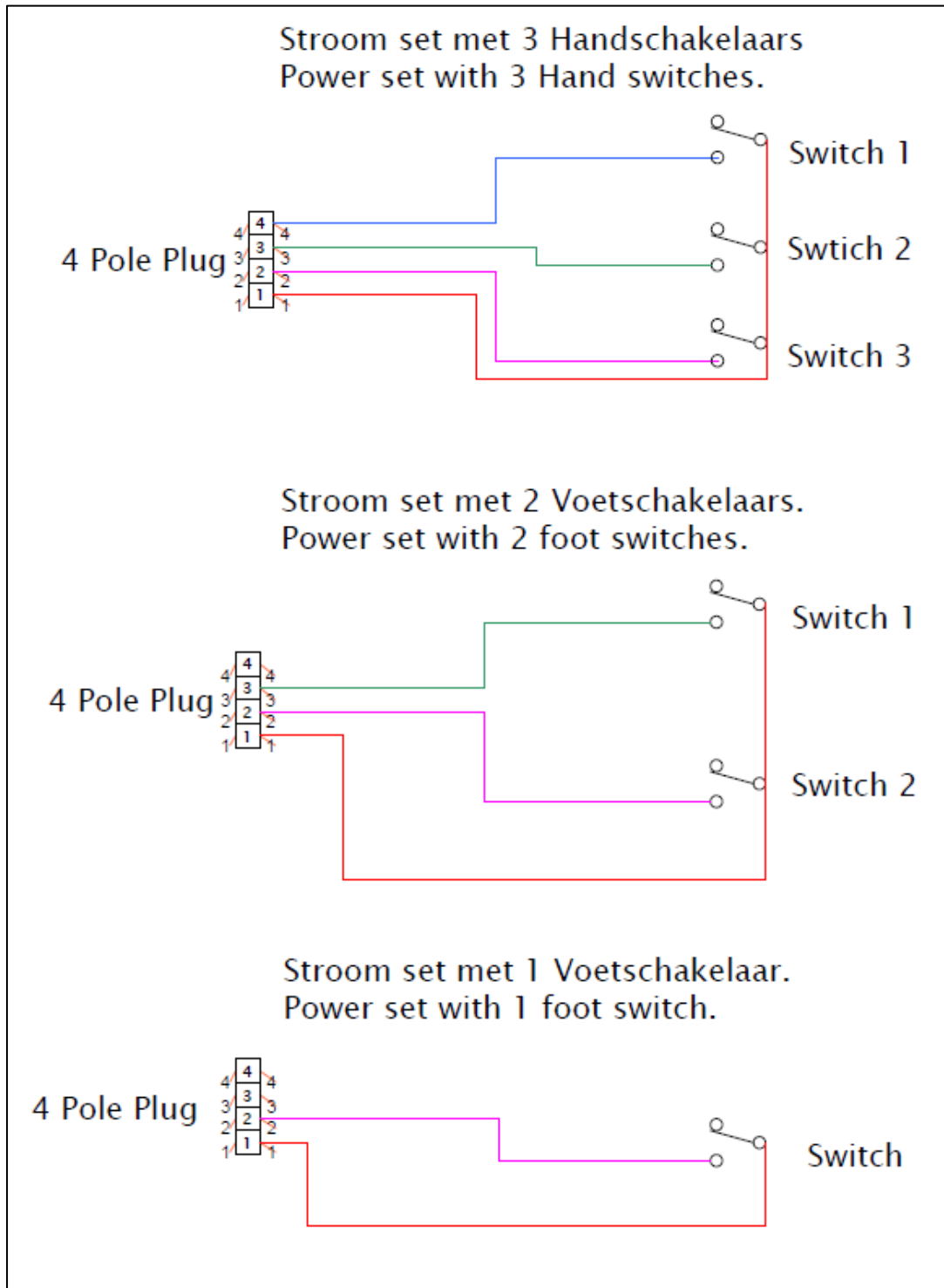

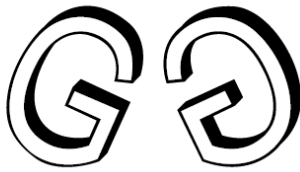

### 8.2 Hydraulic Diagram – Grapple + Saw unit

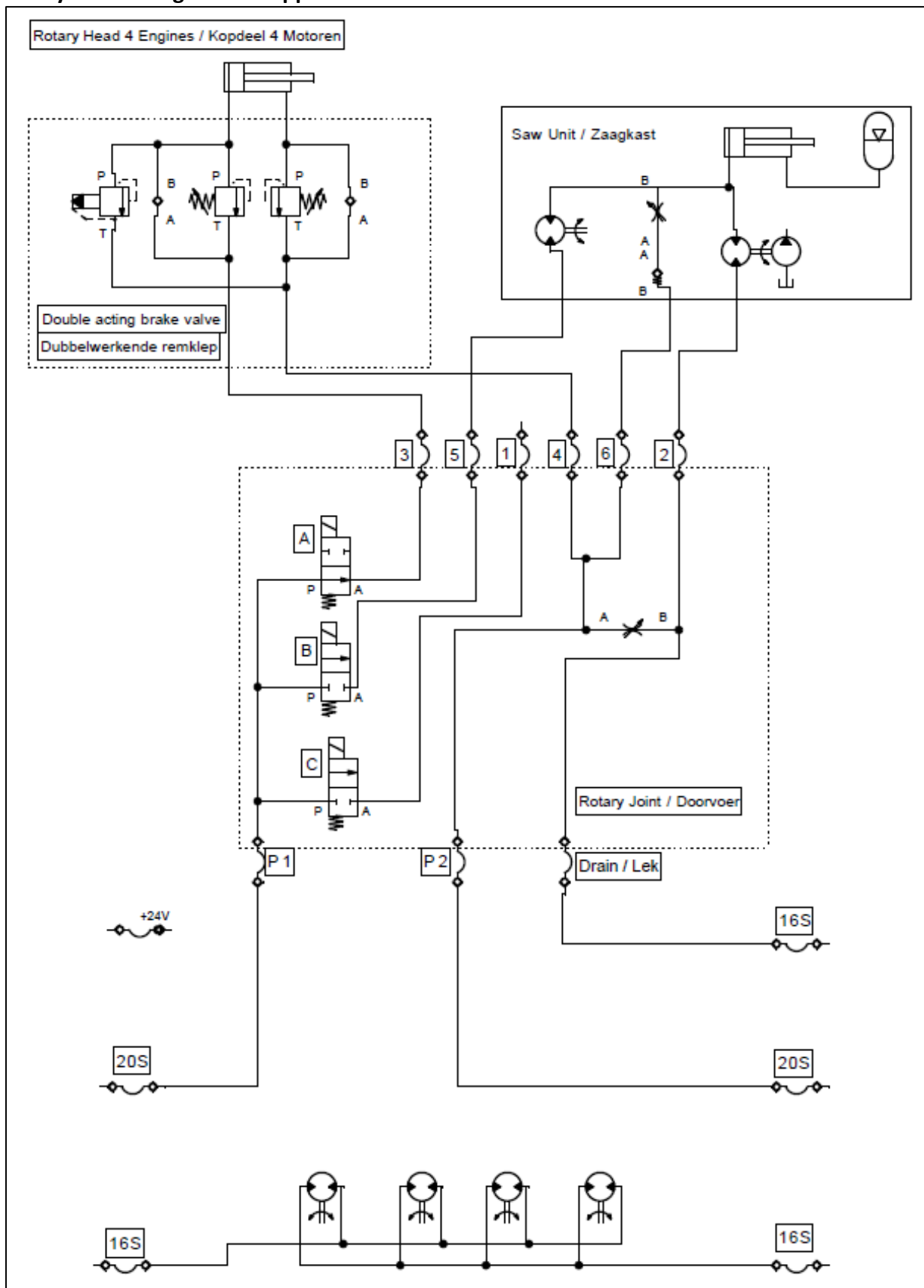

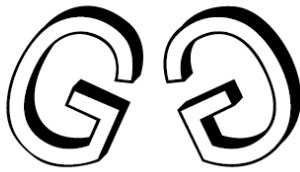

### 8.3 Hydraulic Diagram - Saw Unit Manifold

Hydraulic diagram with rotational lubricating oil pump.

